

Review of Online Monitoring of status of air for Automation with alarm

Miss. Manaswi M. Latthe, Dr. Mrs. S B Patil

Asst. Professor Dr. JJMCOE Jaysingpur

Professor Dr. JJMCOE Jaysingpur

Abstract: Safety is the most vital part of any type of industry. Negligence in the safety part may cause damaging of high quality equipment or may cause loss of human life. In industry safety and security is a fundamental aspect. To avoid unwanted phenomena all industries follows some basic precaution [1]. Communication is the most vital key factor today, to monitor different parameters continuously and to take necessary actions to avoid any types of hazards related to production and security. To avoid loss of material and human health, security and safety system and reliable continuous faithful communication system is essential. To improve security, safety and productivity a reliable communication system must be established. The communication network must not be interrupted at any moment and at any condition. Inside factory, the wired communication network system is not so effective. The reliability and long life of conventional communications systems in harsh environments has always been a problem. Inside factory due to uncomfortable situation the installation cost and maintenance cost is high for wired communication networks.

I. Introduction

Compressed air is an important component of many industries. It affects the quality of the process and the end product. Compressed air often comprises the highest use of electricity in a plant. Since the importance of clean, dry compressed air and the cost associated with it is very high, carefully managing and monitoring of it becomes an important task for any plant. Dew point is one of the most important parameters associated with the quality of compressed air. Dew point is the quantity of moisture in air. Industries needs dry air that is less moisture. 'Power Tool' division is one of the divisions of 'Kulkarni Power Tools'. This division requires high pressured air of 'certain' pressure with 'certain' moisture in that air. Wrong pressure or wrong moisture can harm the machinery. Compressor is used to control the pressure and dryer is used to control the moisture of that air. That is, HIGH pressured DRY air is used for production. To avoid such harms and to avoid separate man power to control these things, company has started this 'automation' based project. After completion of this project user can see parameters of compressor and dryer on display, also higher authority can see this on PC. To take care of pressure, moisture, temperature of compressor and dryer a separate man power is needed. Though man power is made available, there are still chances of accidents and human made errors. In such situations, instead of investing in a 'man power' company could invest in 'machinery (automation)'.

II. Methodology

Block Diagram for Display Unit-

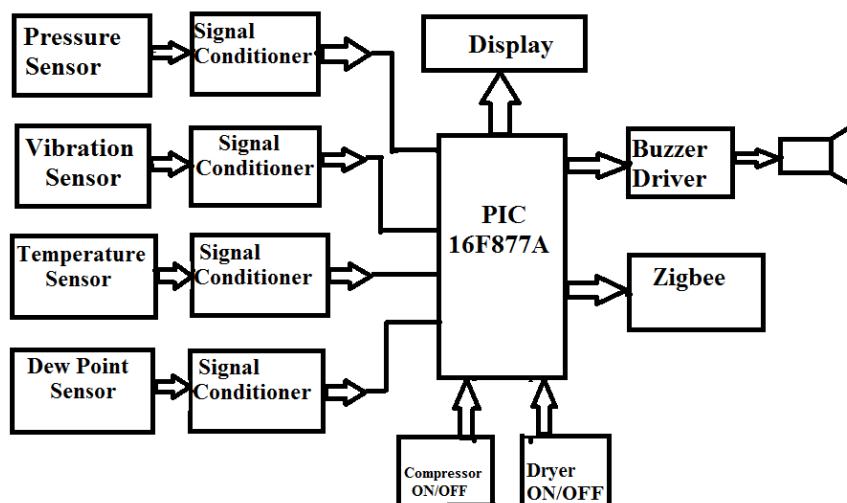

Sensors will sense the current status of air. Output of these sensors is given to signal conditioners. Signal conditioning means manipulating an analog signal in such a way that it meets the requirements of the next stage for further processing. Output of sensors is given to PIC Microcontroller 16F877A. Output of three sensors Temperature, Pressure and Dew point will be displayed on LCD by PIC Microcontroller. Output of vibration sensor will be given to alarm by PIC Microcontroller. If compressor or dryer is not in proper condition, that may create vibrations. If vibrations are beyond limits, that may turn ON alarm. Thus "Prevention is better than Cure". Same data which is displayed on LCD can be displayed on PC also. Here in this paper, this communication between PC and PIC Microcontroller is done by Zigbee.

Block Diagram for Control Unit-

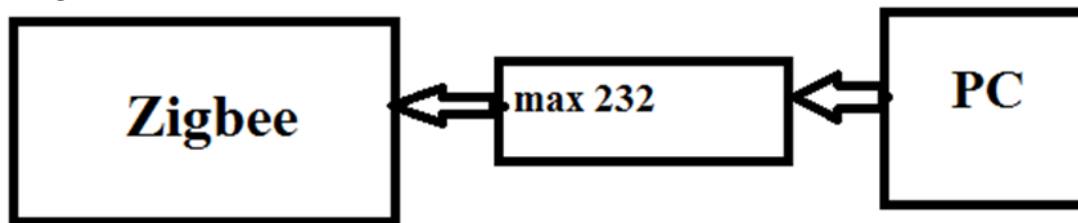

In control unit parameters of air like pressure, temperature and dew point are controlled by PC. Message is sent by PC to max 232 and max 232 to Zigbee. Zigbee sends that messages to Microcontroller. Max 232 is used to send and receive the signals given by the PC and microcontroller . It is used for the serial communication between Zigbee and PC. It also converts the data into serial manner and send to the microcontroller as well as Zigbee transceiver.

III. Hardware Used-

a.Sensors- A sensor is a converter that measures a physical quantity and converts it into a signal which can be read by an observer or by an instrument. In this paper we have used 4 types of sensors-pressure, temperature, dew point and vibration sensor.

b. Signal Conditioners- In electronics, signal conditioning means manipulating an analog signal in such a way that it meets the requirements of the next stage for further processing. Most common use is in analog-to-digital converters. Signal conditioning can include amplification, filtering, converting, range matching, isolation and any other processes required to make sensor output suitable for processing after conditioning.

c. PIC 16F877A- PIC is a family of RISC (Reduced Instruction Set Computer) microcontroller. While 8051 falls somewhat in between RISC and CISC (Complex Instruction Set Computer). PICs are faster, more reliable (high noise immunity) and code-efficient than 8051s. It has internal memory.

d.Buzzer- A **buzzer** is an audio signaling device, which may be mechanical, electromechanical, or piezoelectric. Typical uses of buzzers and beepers include alarm devices, timers and confirmation of user input such as a mouse click or keystroke.

e. Relay- A relay is an electro-magnetic switch which can be used to turn ON or OFF of any machine. Relays allow one circuit to switch a second circuit which is completely separated from the first. In this paper, current situation of compressor and dryer will be displayed on PC along with status of air. From PC user can turn OFF any machine from ON condition by using zigbee without any wired connections. PC will send message to PIC by zigbee. PIC will perform that operation using relay.

f. Zigbee- zigbee is used for wireless communication.

4. Software Used-

a. X-CTU- For PIC to computer interface, a terminal program such as X-CTU needs to be used. Although other terminal programs might work as well, X-CTU software was designed specifically for the ZigBee, and in addition to its terminal functions, it also has functions for testing signal strength, reading, saving, and writing the state of the ZigBee, and updating firmware. The X-CTU program is run on the PC while connected to a Zig-Bee via a serial port.

b. mikroC- In this software, libraries are provided with diagram and coding. It gives easiest possible solution for developing applications for embedded system.

c. Proteus- Proteus is software for microprocessor simulation, schematic capture, and printed circuit board (PCB) design.

d. Visual Basics- To show results on user's PC, visual basic software is used.

3. Algorithm-

1. Initialization of microcontroller kit and display is to be completed.
2. Sensors (Temperature, Pressure, Dew point and Vibration) will generate data by sensing situation of compressed air and compressor respectively.
3. O/P of Temperature, Pressure and Dew point sensor will be displayed on LCD along with ON/OFF conditions of compressor and dryer.
4. The same data which has displayed on LCD is sent to PC by zigbee.
5. Output of vibration sensor is not displayed on LCD. Its output is connected to buzzer.
6. If output of vibration sensor goes beyond limit it will turn ON buzzer so that user would check fitted screws of compressor.
7. User could see ON/OFF conditions of compressor and dryer on his PC along with O/P of sensors.
8. User can change ON/OFF conditions of dryer and compressor from PC. These instructions are sent by zigbee from PC to PIC. PIC will control ON/OFF of dryer and compressor.

IV. Conclusion

'Automation' is the 'main' key of success of any industry. This kind of automation is beneficial to those industries where compressed dry air plays important role. This automation is safe to use and correct for output. It doesn't need high investment and maintenance. It also has high lifetime. X-CTU software is used for zigbee, mikroC is used for programming and using proteus user can check his circuit before mounting. As shown in above pictures we get results.

References

- [1] Purnima and S.R.N. Reddy., "Design of Remote Monitoring and Control System with Automatic Irrigation System using GSM-Bluetooth," *International Journal of Computer Application*, June 2012.
- [2] N. Baker, "Zigbee and bluetooth strengths and weaknesses for industrial applications," *Computing & Control Engineering Journal*, vol. 16, pp. 20–25, Apr./May 2005.
- [3] N. M. Z. Hashim, M. S. Sizali, "Wireless Patient Monitoring System", *International Journal of Science and Research (IJSR)* Volume 2 Issue 8, pp 250-255, 2013.
- [4] Zigbee Development Kit Users Guide (2008), MeshNetics Doc. S-ZDK-451-01 v.1.1.0.
- [5] K.F.Tsang,H.Y.Tung,K.L.Lam,(2009)"Zigbee:From Basics to Designs and Applications", Prentice Hall.
- [6] N. M. Z. Hashim, N. A. Ali, A. S. Jaafar , N. R. Mohamad, L. Salahuddin, N. A. Ishak, "Smart Ordering System via Bluetooth", *International Journal of Computer Trends and Technology (IJCTT)* – volume 4 Issue 7, pp. 2253 2256, 2013.
- [7] N. M. Z. Hashim, S. H. Husin, A. S. Ja'afar, N. A. A. Hamid, "Smart Wiper Control System", *International Journal of Application or Innovation in Engineering & Management (IJAIEM)* Volume 2 Issue 7, pp. 409-415, 2013.
- [8] Y. Y. David Flowers, Kim Otten and N. Rajbharti. (2006, 12) Microchip stack for the zigbee protocol. Microchip Technology Inc. [Online]. Available: <http://www.microchip.com>
- [9] D. Flowers. (2006) Microcontroller Technology Inc. [Online]. Available: <http://www.microcontroller.com>
- [10] Microchip technology Inc, (2002), MPLAB C18 C COMPILER USER's GUIDE.pdf.
- [11] Transfer Multisort Elektronik Company (1990), DISPLAY ELEKTRONIK DEM16217-SYH-LY - Display: LCD; alphanumeric; STN Positive; 16x2; LED; (84x44x8.5mm) Datasheet, pdf.
- [12] N. M. Z. Hashim, S. N. K. S. Mohamed, "Development of Student Information System", *International Journal of Science and Research (IJSR)* Volume 2 Issue 8, pp 256-260, 2013.
- [13] N. M. Z. Hashim, N. A. M. M. Arifin, "Laboratory Inventory System", *International Journal of Science and Research (IJSR)* Volume 2 Issue 8, pp 261-264, 2013.